

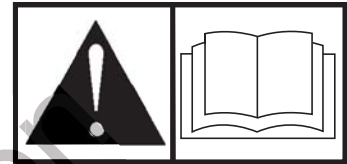

ELITE Series™

PORTABLE GENERATORS

Operator's Manual



This generator is rated in accordance with CSA (Canadian Standards Association) standard C22.2 No. 100-04 (motors and generators).

BRIGGS & STRATTON POWER PRODUCTS GROUP, LLC
MILWAUKEE, WISCONSIN, U.S.A.

Manual No. 317663GS Revision -



0 24847 90343 0

Thank you for purchasing this quality-built Briggs & Stratton® generator. We are pleased that you've placed your confidence in the Briggs & Stratton brand. When operated and maintained according to the instructions in this manual, your Briggs & Stratton generator will provide many years of dependable service.

This manual contains safety information to make you aware of the hazards and risks associated with generator products and how to avoid them. This generator is designed and intended only for supplying electrical power for operating compatible electrical lighting, appliances, tools and motor loads, and is not intended for any other purpose. It is important that you read and understand these instructions thoroughly before attempting to start or operate this equipment. **Save these original instructions for future reference.**

This generator requires final assembly before use. Refer to the *Assembly* section of this manual for instructions on final assembly procedures. Follow the instructions completely.

Where to Find Us

You never have to look far to find Briggs & Stratton support and service for your generator. Consult your Yellow Pages. There are over 30,000 Briggs & Stratton authorized service dealers worldwide who provide quality service. You can also contact Briggs & Stratton Customer Service by phone at **(800) 743-4115**, or on the Internet at BRIGGSandSTRATTON.COM.

Generator

Model Number

--	--	--	--	--	--	--	--

Revision

--	--

Serial Number

--	--	--	--	--	--	--	--	--	--	--	--	--	--	--

Engine

Model Number

--	--	--	--	--	--	--	--

Type Number

--	--	--	--	--	--	--	--

Code Number

--	--	--	--	--	--	--	--	--	--	--	--	--	--	--	--	--	--

Date Purchased

--	--	--	--	--	--	--	--

Copyright © 2012. Briggs & Stratton Power Products Group, LLC
Milwaukee, WI, USA. All rights reserved.
BRIGGS & STRATTON POWER PRODUCTS is a registered
trademark of Briggs & Stratton Corporation
Milwaukee, WI, USA

Table of Contents

Operator Safety	4
Equipment Description	4
Important Safety Information	4
Assembly	7
Unpack Generator	7
Shipment Contents	7
Install Wheel Kit	7
Add Engine Oil	9
Add Fuel	9
System Ground	10
Connecting to a Building's Electrical System	10
Generator Location	10
Features and Controls	11
Cord Sets and Receptacles	13
Battery Charger	14
Operation	15
Starting the Engine	15
Connecting Electrical Loads	16
Stopping the Engine	16
Operating Automatic Idle Control	16
Oil Pressure Shutdown	16
Charging a Battery	17
Cold Weather Operation	17
Don't Overload Generator	19
Maintenance	20
Maintenance Schedule	20
Generator Maintenance	20
Battery Maintenance	20
Fuel Valve Maintenance	21
Engine Maintenance	21
Storage	24
Troubleshooting	25
Warranties	26
Emissions Control System Warranty	26
Generator Owner Warranty	28
Specifications	30
Product Specifications	30
Common Service Parts	30

Operator Safety

Equipment Description



Read this manual carefully and become familiar with your generator. Know its applications, its limitations and any hazards involved.

The generator is an engine-driven, revolving field, alternating current (AC) generator. It was designed to supply electrical power for operating compatible electrical lighting, appliances, tools and motor loads. The generator's revolving field is driven at about 3,600 rpm by a twin-cylinder engine.

NOTICE Exceeding generators wattage/amperage capacity could damage generator and/or electrical devices connected to it.

- DO NOT exceed the generator's wattage/amperage capacity. See *Don't Overload Generator* in the *Operation* section.

Every effort has been made to ensure that the information in this manual is both accurate and current. However, the manufacturer reserves the right to change, alter or otherwise improve the generator and this documentation at any time without prior notice.

The Emission Control System for this generator is warranted for standards set by the Environmental Protection Agency and the California Air Resources Board.

Important Safety Information

The manufacturer cannot possibly anticipate every possible circumstance that might involve a hazard. The warnings in this manual, and the tags and decals affixed to the unit are, therefore, not all-inclusive. If you use a procedure, work method or operating technique that the manufacturer does not specifically recommend, you must satisfy yourself that it is safe for you and others. You must also make sure that the procedure, work method or operating technique that you choose does not render the generator unsafe.

Safety Symbols and Meanings



Toxic Fumes



Kickback



Electrical Shock



Fire



Explosion



Operator's Manual



Moving Parts



Flying Objects



Hot Surface



Explosive Pressure



Chemical Burn

▲ The safety alert symbol indicates a potential personal injury hazard. A signal word (DANGER, WARNING, or CAUTION) is used with the alert symbol to designate a degree or level of hazard seriousness. A safety symbol may be used to represent the type of hazard. The signal word **NOTICE** is used to address practices not related to personal injury.

▲ **DANGER** indicates a hazard which, if not avoided, *will* result in death or serious injury.

▲ **WARNING** indicates a hazard which, if not avoided, *could* result in death or serious injury.

▲ **CAUTION** indicates a hazard which, if not avoided, *could* result in minor or moderate injury.

NOTICE address practices not related to personal injury.

▲ DANGER

Using a generator indoors CAN KILL YOU IN MINUTES.

Generator exhaust contains carbon monoxide. This is a poison you cannot see or smell.



NEVER use inside a home or garage, EVEN IF doors and windows are open.



Only use OUTSIDE and far away from windows, doors, and vents.

▲ WARNING Running engine gives off carbon monoxide, an odorless, colorless, poison gas. Breathing carbon monoxide could result in death, serious injury, headache, fatigue, dizziness, vomiting, confusion, seizures, nausea or fainting.

- Operate this product **ONLY** outdoors.
- Install a battery operated carbon monoxide alarm near the bedrooms.
- Keep exhaust gas from entering a confined area through windows, doors, ventilation intakes, or other openings.
- **DO NOT** operate this product inside any building, carport, porch, mobile equipment, marine applications, or enclosure, even if windows and doors are open.

▲ WARNING Storage batteries give off explosive hydrogen gas during recharging. Hydrogen gas stays near battery for a long time after battery has been charged. Slightest spark could ignite hydrogen causing explosion resulting in death, serious injury and/or property damage.

- Battery electrolyte fluid contains acid and is extremely caustic. Contact with battery fluid could cause chemical burns resulting in serious injury and/or property damage.
- **DO NOT** allow any open flame, spark, heat, or lit cigarette during and for several minutes after charging a battery.
- Wear protective goggles, rubber apron, and rubber gloves.
- **DO NOT** continue to charge a battery that becomes hot or is fully charged.
- **DO NOT** leave battery unattended.

▲ WARNING The engine exhaust from this product contains chemicals known to the State of California to cause cancer, birth defects, or other reproductive harm.

▲ WARNING Certain components in this product and related accessories contain chemicals known to the State of California to cause cancer, birth defects or other reproductive harm. Wash hands after handling.

▲ WARNING Starter cord kickback (rapid retraction) will pull hand and arm toward engine faster than you can let go which could cause broken bones, fractures, bruises, or sprains resulting in serious injury.

- When starting engine, pull cord slowly until resistance is felt and then pull rapidly to avoid kickback.
- **NEVER** start or stop engine with electrical devices plugged in and turned on.

▲ WARNING Fuel and its vapors are extremely flammable and explosive which could cause burns, fire or explosion resulting in death, serious injury and/or property damage.



WHEN ADDING OR DRAINING FUEL

- Turn generator engine **OFF** and let it cool at least 2 minutes before removing fuel cap. Loosen cap slowly to relieve pressure in tank.
- Fill or drain fuel tank outdoors.
- **DO NOT** overfill tank. Allow space for fuel expansion.
- If fuel spills, wait until it evaporates before starting engine.
- Keep fuel away from sparks, open flames, pilot lights, heat, and other ignition sources.
- Check fuel lines, tank, cap and fittings frequently for cracks or leaks. Replace if necessary.
- **DO NOT** light a cigarette or smoke.

WHEN STARTING EQUIPMENT

- Ensure spark plug, muffler, fuel cap, and air cleaner are in place.
- **DO NOT** crank engine with spark plug removed.

WHEN OPERATING EQUIPMENT

- **DO NOT** operate this product inside any building, carport, porch, mobile equipment, marine applications, or enclosure.
- **DO NOT** tip engine or equipment at angle which causes fuel to spill.
- **DO NOT** stop engine by moving choke control to "**Choke**" position (I\I).

WHEN TRANSPORTING, MOVING OR REPAIRING EQUIPMENT

- Transport/move/repair with fuel tank **EMPTY** or with fuel shutoff valve **OFF**.
- **DO NOT** tip engine or equipment at angle which causes fuel to spill.
- Disconnect spark plug wire.

WHEN STORING FUEL OR EQUIPMENT WITH FUEL IN TANK

- Store away from furnaces, stoves, water heaters, clothes dryers, or other appliances that have pilot light or other ignition source because they could ignite fuel vapors.

▲ WARNING

- This generator does not meet U. S. Coast Guard Regulation 33CFR-183 and should not be used on marine applications.
- Failure to use the appropriate U. S. Coast Guard approved generator could result in death or serious injury and/or property damage.

⚠ WARNING Generator voltage could cause electrical shock or burn resulting in death or serious injury.



- Use approved transfer equipment to prevent backfeed by isolating generator from electric utility workers.
- When using generator for backup power, notify utility company.
- Use a ground fault circuit interrupter (GFCI) in any damp or highly conductive area, such as metal decking or steel work.
- DO NOT touch bare wires or receptacles.
- DO NOT use generator with electrical cords which are worn, frayed, bare or otherwise damaged.
- DO NOT operate generator in the rain or wet weather.
- DO NOT handle generator or electrical cords while standing in water, while barefoot, or while hands or feet are wet.
- DO NOT allow unqualified persons or children to operate or service generator.

⚠ WARNING Exhaust heat/gases could ignite combustibles, structures or damage fuel tank causing a fire, resulting in death, serious injury and/or property damage.



Contact with muffler area could cause burns resulting in serious injury.

- DO NOT touch hot parts and AVOID hot exhaust gases.
 - Allow equipment to cool before touching.
 - Keep at least 5 feet (1.5 m) of clearance on all sides of generator including overhead.
 - It is a violation of California Public Resource Code, Section 4442, to use or operate the engine on any forest-covered, brush-covered, or grass-covered land unless the exhaust system is equipped with a spark arrester, as defined in Section 4442, maintained in effective working order. Other states or federal jurisdictions may have similar laws.
- Contact the original equipment manufacturer, retailer, or dealer to obtain a spark arrester designed for the exhaust system installed on this engine.
- Replacement parts must be the same and installed in the same position as the original parts.

⚠ WARNING Unintentional sparking could cause fire or electric shock resulting in death or serious injury.



WHEN ADJUSTING OR MAKING REPAIRS TO YOUR GENERATOR

- Disconnect the spark plug wire from the spark plug and place the wire where it cannot contact spark plug.

WHEN TESTING FOR ENGINE SPARK

- Use approved spark plug tester.
- DO NOT check for spark with spark plug removed.

⚠ WARNING Starter and other rotating parts could entangle hands, hair, clothing, or accessories resulting in serious injury.



- NEVER operate generator without protective housing or covers.
- DO NOT wear loose clothing, jewelry or anything that could be caught in the starter or other rotating parts.
- Tie up long hair and remove jewelry.

⚠ CAUTION Excessively high operating speeds could result in minor injury and/or generator damage. Excessively low speeds impose a heavy load.

- DO NOT tamper with governor spring, links or other parts to increase engine speed. Generator supplies correct rated frequency and voltage when running at governed speed.
- DO NOT modify generator in any way.

NOTICE Exceeding generators wattage/ampere capacity could damage generator and/or electrical devices connected to it.

- DO NOT exceed the generator's wattage/ampere capacity. See *Don't Overload Generator* in the *Operation* section.
- Start generator and let engine stabilize before connecting electrical loads.
- Connect electrical loads in OFF position, then turn ON for operation.
- Turn electrical loads OFF and disconnect from generator before stopping generator.

NOTICE Improper treatment of generator could damage it and shorten its life.

- Use generator only for intended uses.
- If you have questions about intended use, ask dealer or contact local service center.
- Operate generator only on level surfaces.
- DO NOT expose generator to excessive moisture, dust, dirt, or corrosive vapors.
- DO NOT insert any objects through cooling slots.
- If connected devices overheat, turn them off and disconnect them from generator.
- Shut off generator if:
 - electrical output is lost;
 - equipment sparks, smokes, or emits flames;
 - unit vibrates excessively.

Assembly

Your generator requires some assembly and is ready for use after it has been properly serviced with the recommended oil and fuel.

If you have any problems with the assembly of your generator, please call the generator helpline at **(800) 743-4115**. If calling for assistance, please have the model, revision, and serial number from the identification label available. See *Controls and Features* for identification label location.

Unpack Generator

1. Set the carton on a rigid, flat surface.
2. Remove everything from carton except generator.
3. Open carton completely by cutting each corner from top to bottom.
4. Leave generator on carton to install wheel kit.

Shipment Contents

The generator is supplied with:

- Engine oil
- Operator's manual
- Battery float charger
- Battery charge cables
- Wheel kit
- 120/240 Volt, 30 Amp locking plug
- 120 Volt, 30 Amp locking plug
- 120 Volt, 20 Amp locking plug
- Storage cover

Install Wheel Kit

NOTICE Wheel kit is not intended for over-the-road use.

You will need the following tools to install these components:

- Socket wrench with a 9/16" or 14 mm socket
- Pliers
- Safety glasses

Install the wheel kit as follows:

1. Tip generator so that engine end is down.
2. Slide axle (**A**) through both mounting brackets.
3. Slide a wheel (**B**) over axle.

NOTICE Be sure to install both wheels with the air inflation valve on the outboard side.

4. Place a washer (**C**) on axle and then place an e-ring (**D**) in axle groove.

CAUTION E-rings could cause eye injury. E-rings could spring back and become airborne when installing or removing, resulting in moderate injury.

- Always wear eye protection when installing/removing e-rings.

5. Install e-ring with pliers, squeezing from top of e-ring to bottom of axle.
6. Repeat steps 3 through 5 to secure second wheel.

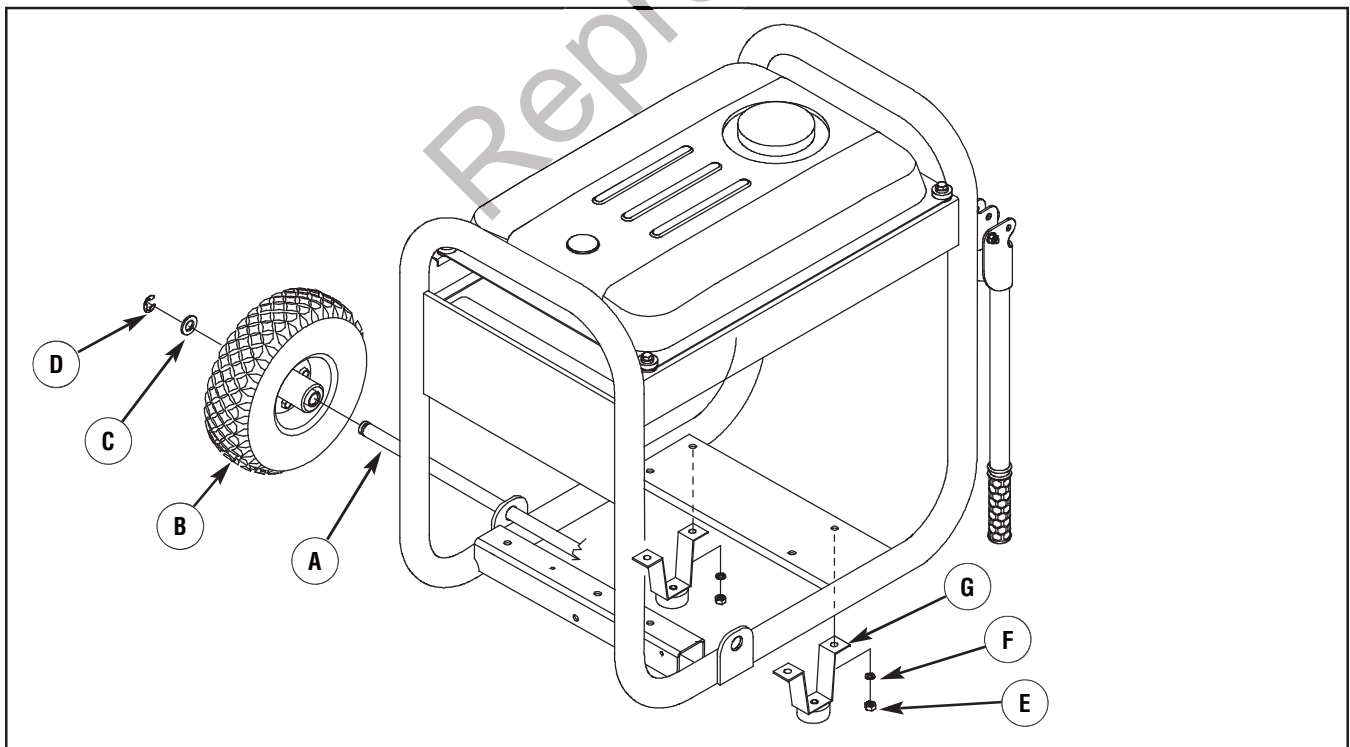

7. Tip generator so that engine side is up.
8. Using a 9/16" or 14 mm socket wrench, remove one existing hex nut (E) and lock washer (F) from engine vibration mounts.
9. Slide support leg (G) onto engine vibration mount stud and attach with the lock washer and hex nut. DO NOT fully tighten.
10. Repeat steps 8 and 9 for second existing hex nut and lock washer on engine vibration mounts.
11. Using a 9/16" or 14 mm socket wrench, tighten both hex nuts and lock washers.
12. Repeat steps 8 through 11 for second support leg on other side.
13. Return generator to normal operating position (resting on wheels and support leg).
14. Check each fastener to ensure it is secure and the tires are inflated between 15-40 PSI.

Attach Negative Battery Cable

Your unit is equipped with electric start capability but can be started manually. If you choose not to use the electric start feature, you do not need to connect the negative battery cable.

The sealed battery on the generator pre-installed except for the negative (black) battery cable.

▲ WARNING Battery posts, terminals and related accessories contain lead and lead compounds - chemicals known to the State of California to cause cancer and reproductive harm. Wash hands after handling.

To install:

1. Cut off tie wrap securing loose end of negative (black) cable.
2. Using an 8 mm or 5/16" socket wrench, remove screw (A), lock washer (B) and flat washer (C) on negative battery terminal.

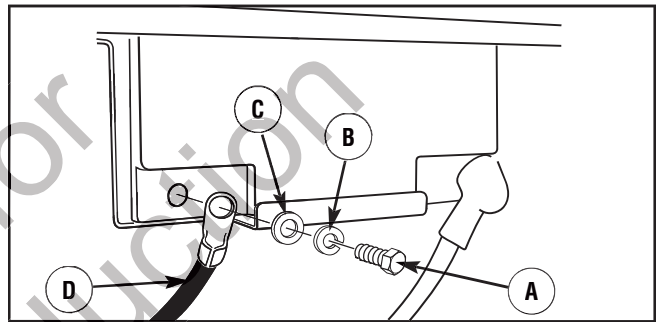

3. Slide lock washer, flat washer and negative battery cable (D) over screw as shown.
4. Reattach screw to negative battery terminal and tighten.
5. Verify that connections to battery and generator are tight and secure.

NOTICE If your battery is discharged, charge prior to use following the instructions in the section *Battery Charger*.

Add Engine Oil

1. Place generator on a flat, level surface.
2. Clean area around oil fill cap and remove oil fill cap.
3. Using oil funnel (optional), slowly pour contents of both provided oil bottles into oil fill opening to the "Full" mark on dipstick.

NOTICE Improper treatment of generator could damage it and shorten its life.

- DO NOT attempt to crank or start the engine before it has been properly serviced with the recommended oil. This could result in an engine failure.
4. Replace and tighten both the oil fill cap and dipstick.

Add Fuel

Fuel must meet these requirements:

- Clean, fresh, unleaded gasoline.
- A minimum of 87 octane/87 AKI (91 RON). For high altitude use, see *High Altitude*.
- Gasoline with up to 10% ethanol (gasohol) or up to 15% MTBE (methyl tertiary butyl ether) is acceptable.

NOTICE Avoid generator damage.

Failure to follow Operator's Manual for fuel recommendations voids warranty.

- DO NOT use unapproved gasoline such as E85.
- DO NOT mix oil in gasoline.
- DO NOT modify engine to run on alternate fuels.

To protect the fuel system from gum formation, mix in a fuel stabilizer when adding fuel. See *Storage*. All fuel is not the same. If you experience starting or performance problems after using fuel, switch to a different fuel provider or change brands. This engine is certified to operate on gasoline. The emission control system for this engine is EM (Engine Modifications).

▲ WARNING Fuel and its vapors are extremely flammable and explosive which could cause burns, fire or explosion resulting in death, serious injury and/or property damage.



WHEN ADDING FUEL

- Turn generator engine OFF and let it cool at least 2 minutes before removing fuel cap. Loosen cap slowly to relieve pressure in tank.
- Fill fuel tank outdoors.
- DO NOT overfill tank. Allow space for fuel expansion.
- If fuel spills, wait until it evaporates before starting engine.
- Keep fuel away from sparks, open flames, pilot lights, heat, and other ignition sources.
- Check fuel lines, tank, cap and fittings frequently for cracks or leaks. Replace if necessary.
- DO NOT light a cigarette or smoke.

1. Clean area around fuel fill cap, remove cap.
2. Slowly add unleaded gasoline (A) to fuel tank (B). Be careful not to overfill. Allow about 1.5" (4 cm) of tank space (C) for fuel expansion.

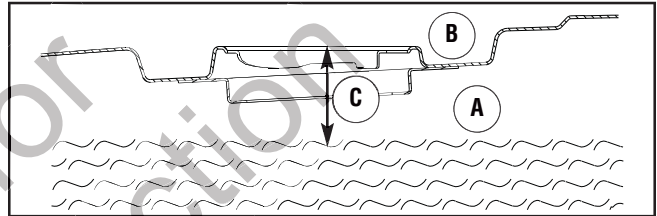

3. Install fuel cap and let any spilled fuel evaporate before starting engine.

High Altitude

At altitudes over 5,000 feet (1524 meters), a minimum 85 octane / 85 AKI (89 RON) gasoline is acceptable. To remain emissions compliant, high altitude adjustment is required. Operation without this adjustment will cause decreased performance, increased fuel consumption, and increased emissions. See an authorized dealer for high altitude adjustment information. Operation of the engine at altitudes below 2,500 feet (762 meters) with the high altitude kit is not recommended.

System Ground

The generator has a system ground that connects the generator frame components to the ground terminals on the AC output receptacles. The system ground is connected to the AC neutral wire (the neutral is bonded to the generator frame).

Special Requirements

There may be Federal or State Occupational Safety and Health Administration (OSHA) regulations, local codes, or ordinances that apply to the intended use of the generator. Please consult a qualified electrician, electrical inspector, or the local agency having jurisdiction:

- In some areas, generators are required to be registered with local utility companies.
- If the generator is used at a construction site, there may be additional regulations which must be observed.

Connecting to a Building's Electrical System

Connections for standby power to a building's electrical system must be made by a qualified electrician. The connection must isolate the generator power from utility power or other alternative power sources and must comply with all applicable laws and electrical codes.

⚠ WARNING Generator voltage could cause electrical shock or burn resulting in death or serious injury.

- Use approved transfer equipment to prevent backfeed by isolating generator from electric utility workers.
- When using generator for backup power, notify utility company.
- Use a ground fault circuit interrupter (GFCI) in any damp or highly conductive area, such as metal decking or steel work.
- DO NOT touch bare wires or receptacles.
- DO NOT use generator with electrical cords which are worn, frayed, bare or otherwise damaged.
- DO NOT operate generator in the rain or wet weather.
- DO NOT handle generator or electrical cords while standing in water, while barefoot, or while hands or feet are wet.
- DO NOT allow unqualified persons or children to operate or service generator.

Generator Location

Clearances and Air Movement

⚠ WARNING Exhaust heat/gases could ignite combustibles, structures or damage fuel tank causing a fire, resulting in death, serious injury and/or property damage.

- Keep at least 5 ft. (1.5 m) clearance on all sides of generator including overhead.

Place generator outdoors in an area that will not accumulate deadly exhaust gas. DO NOT place generator where exhaust gas (A) could accumulate and enter inside or be drawn into a potentially occupied building. Ensure exhaust gas is kept away from any windows, doors, ventilation intakes, or other openings that can allow exhaust gas to collect in a confined area. Prevailing winds and air currents should be taken into consideration when positioning generator.

⚠ DANGER

Using a generator indoors CAN KILL YOU IN MINUTES.

Generator exhaust contains carbon monoxide. This is a poison you cannot see or smell.

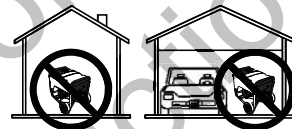

NEVER use inside a home or garage, EVEN IF doors and windows are open.

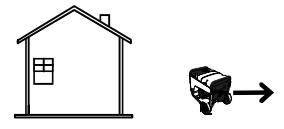

Only use OUTSIDE and far away from windows, doors, and vents.

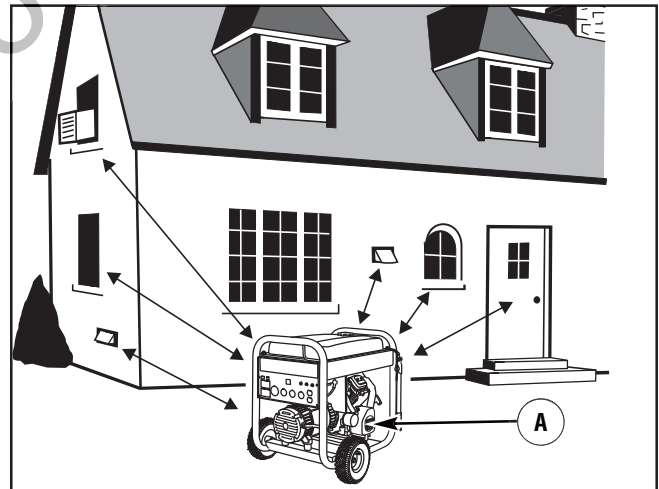

Features and Controls



Read this Operator's Manual and safety rules before operating your generator.

Compare the illustrations with your generator, to familiarize yourself with the locations of various controls and adjustments. Save this manual for future reference.

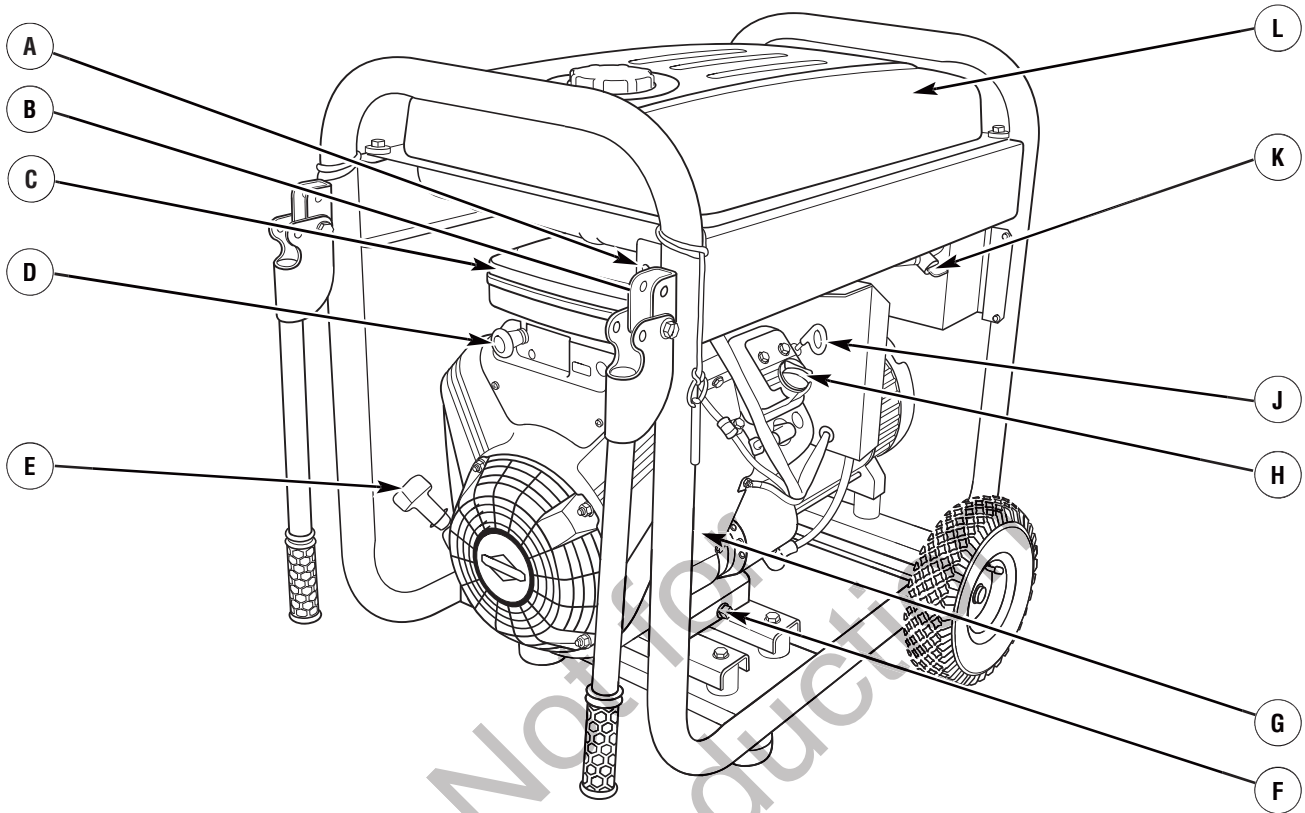

A - Battery Float Charger Jack — Use battery float charger jack to keep the starting battery charged and ready for use.

B - Start Switch — Push to start the engine.

C - Air Cleaner — Protects engine by filtering dust and debris out of intake air.

D - Choke Control — Used when starting a cold engine.

E - Recoil Starter — Used to start the engine manually.

F - Oil Drain Plug — Drain engine oil here.

G - Engine Identification — Provides model, type and code of engine. Please have these readily available if calling for assistance.

H - Oil Fill Cap — Fill engine with oil here.

J - Oil Dipstick — Check engine oil here.

K - Fuel Valve — Used to turn fuel supply on and off to engine.

L - Fuel Tank — Capacity of seven (7) U.S. gallons (26.5 l).

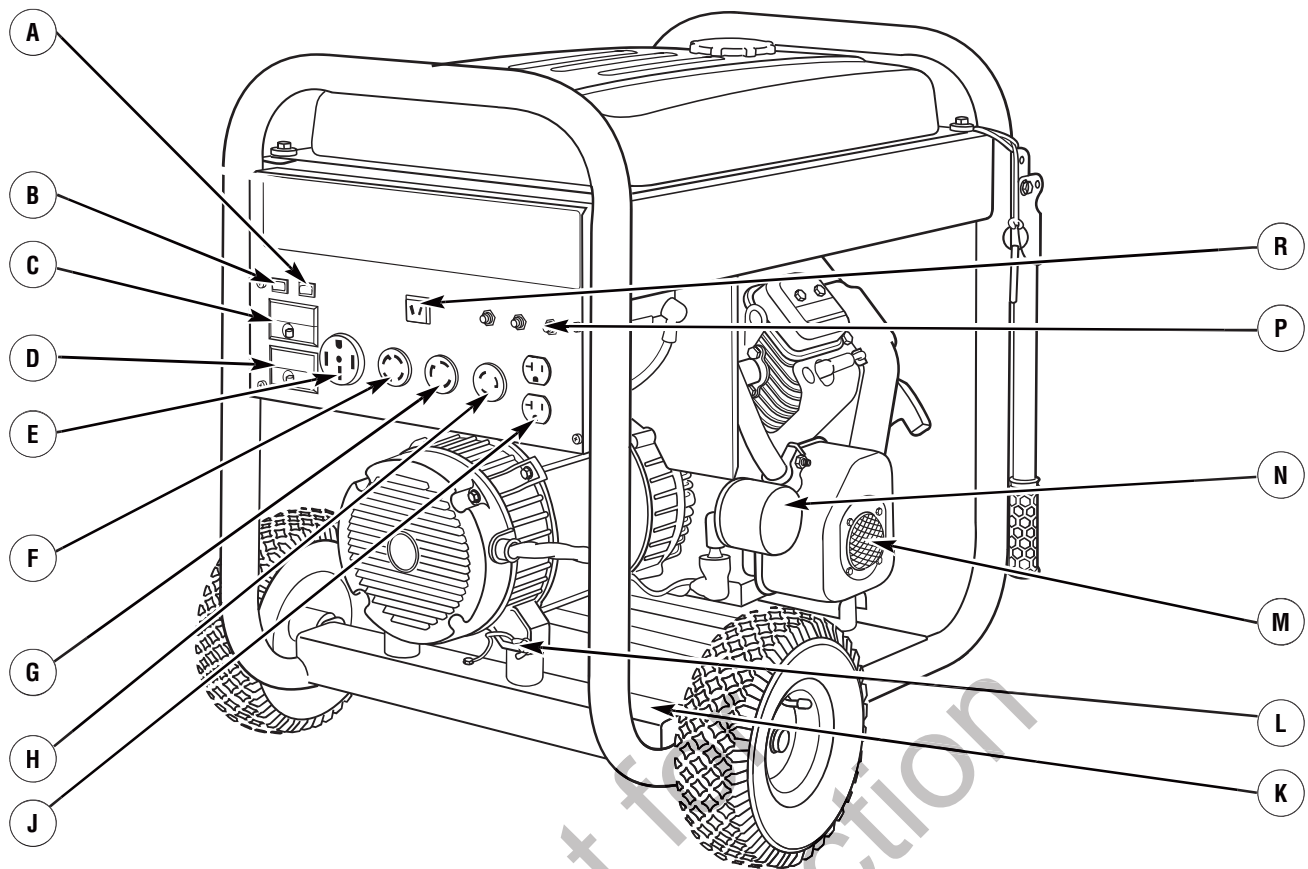

A - Idle Control Switch — Use this switch to turn the idle control feature on and off.

B - Run/Stop Switch — Set this switch to "Run" before starting. Set switch to "Stop" to switch off engine.

C - 30 Amp, 2 Pole Circuit Breaker — The 120/240 Volt AC, 30A locking receptacle and the 120 Volt AC, 30A locking receptacle is provided with a 2 pole circuit breaker to protect the generator against electrical overload.

D - Main Circuit Breaker — The 120/240 Volt AC, 50A receptacle is provided with a 2 pole circuit breaker to protect the generator against electrical overload. This circuit breaker also controls all AC receptacles.

E - 120/240 Volt AC, 50 Amp Receptacle — May be used to supply electrical power for the operation of 120 and/or 240 Volt AC, 50 Amp, single phase, 60 Hz electrical loads.

F - 120/240 Volt AC, 30 Amp Locking Receptacle — May be used to supply electrical power for the operation of 120 and/or 240 Volt AC, 30 Amp, single phase, 60 Hz electrical, lighting, appliance, tool and motor loads.

G - 120 Volt AC, 30 Amp Locking Receptacle — May be used to supply electrical power for the operation of 120 Volt AC, 30 Amp, single phase, 60 Hz electrical lighting, appliance, tool and motor loads.

H - 120 Volt AC, 20 Amp Locking Receptacle — May be used to supply electrical power for the operation of 120 Volt AC, 20 Amp, single phase, 60 Hz electrical lighting, appliance, tool and motor loads.

J - 120 Volt AC, 20 Amp, Duplex Receptacle — May be used to supply electrical power for the operation of 120 Volt AC, 20 Amp, single phase, 60 Hz electrical, lighting, appliance, tool and motor loads.

K - Identification Label — Provides model and serial number of generator. Please have these readily available if calling for assistance.

L - Grounding Fastener — Consult your local agency having jurisdiction for grounding requirements in your area.

M - Spark Arrester Muffler — Exhaust muffler lowers engine noise and is equipped with a spark arrester screen.

N - Oil Filter — Filters engine oil to prolong engine life.

P - Circuit Breakers (AC) — The 120 Volt AC, 20A duplex receptacle and the 120 Volt AC, 20A locking receptacle is provided with "push to reset" circuit breakers to protect the generator against electrical overload.

R - 12 Volt DC Receptacle — Use this receptacle with battery charge cables to charge a 12 Volt battery. This receptacle is protected by a 10 Amp auto reset circuit breaker.

Cord Sets and Receptacles

Use only high quality, well-insulated, grounded extension cords with the generator's receptacles. Inspect extension cords before each use.

Check the ratings of all extension cords before you use them. Extension cord sets used should be rated for 125 Volts AC loads 20 Amps or greater. Check operator's manuals of devices to be powered for the manufacturer's recommendations.

Keep extension cords as short as possible to minimize voltage drop.

⚠ WARNING Damaged or overloaded electrical cords could overheat, arc, and burn resulting in death, serious injury, and/or property damage.

- ONLY use cords rated for your loads.
- Follow all safeties on electrical cords.
- Inspect cord sets before each use.

120/240 Volt AC, 50 Amp Receptacle

Use a NEMA 14-50 plug with this receptacle. Connect a 4-wire cord set rated for 250 Volt AC loads at 50 Amps to the plug.

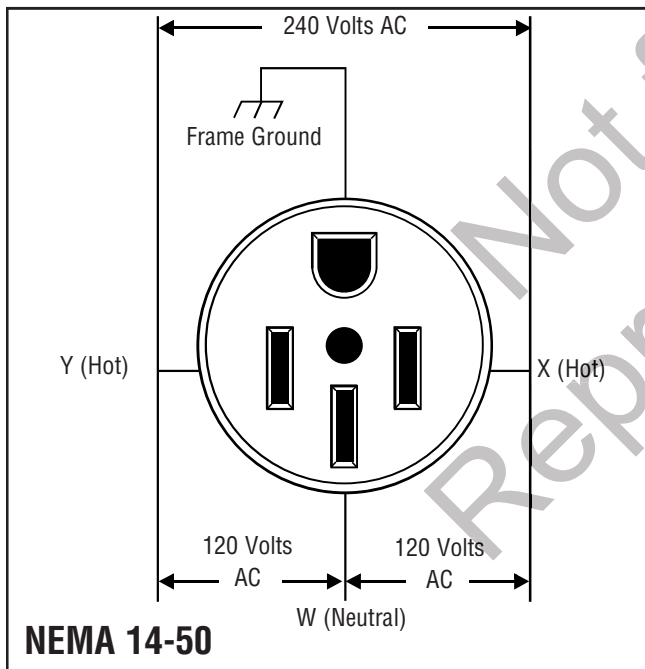

This receptacle powers 120/240 Volt AC, 60 Hz, single phase loads requiring up to 10,000 watts of power (10.0 kW) at 41.6 Amps for 240 Volts or two independent 120 Volt loads. The outlet is protected by a 2 pole circuit breaker.

NOTICE Receptacles may be marked with rating value greater than generator output capacity.

- NEVER attempt to power a device requiring more amperage than generator or receptacle can supply.
- DO NOT overload the generator. See *Don't Overload Generator*.

120/240 Volt AC, 30 Amp, Locking Receptacle

Use a NEMA L14-30 plug with this receptacle. Connect a 4-wire cord set rated for 250 Volt AC loads at 30 Amps (or greater). You can use the same 4-wire cord if you plan to run a 120 Volt load.

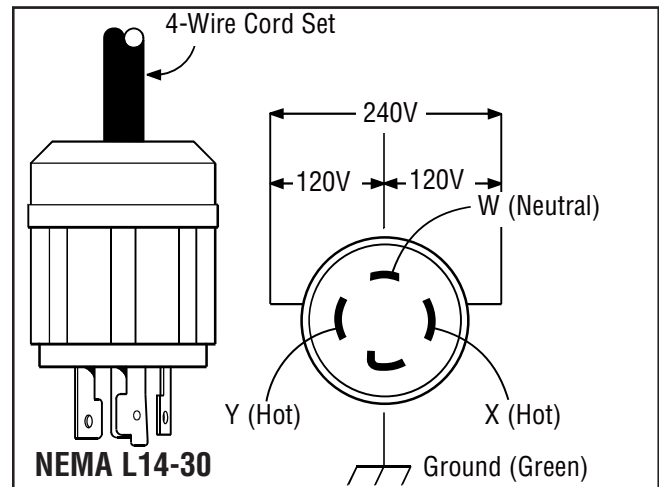

This receptacle powers 120/240 Volt AC, 60 Hz, single phase loads requiring up to 7,200 watts of power (7.2 kW) at 30 Amps for 240 Volts or two independent 120 Volt loads at 30 Amps each. The outlet is protected by a 2 pole circuit breaker.

120 Volt AC, 30 Amp Locking Receptacle

Use a NEMA L5-30 plug with this receptacle. Connect a 3-wire cord set rated for 125 Volt AC loads at 30 Amps to the plug.

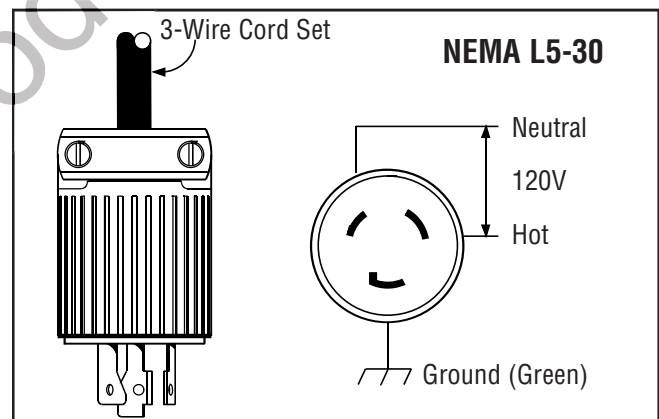

Use this receptacle to operate 120 Volt AC, 60 Hz, single phase loads requiring up to 3,600 watts (3.6 kW) of power at 30 Amps. The outlet is protected by a 2 pole circuit breaker.

120 Volt, 20 Amp Locking Type Receptacle

Use a NEMA L5-20 plug with this receptacle. Connect a 3-wire cord set rated for 125 Volt AC loads at 20 Amps to the plug.

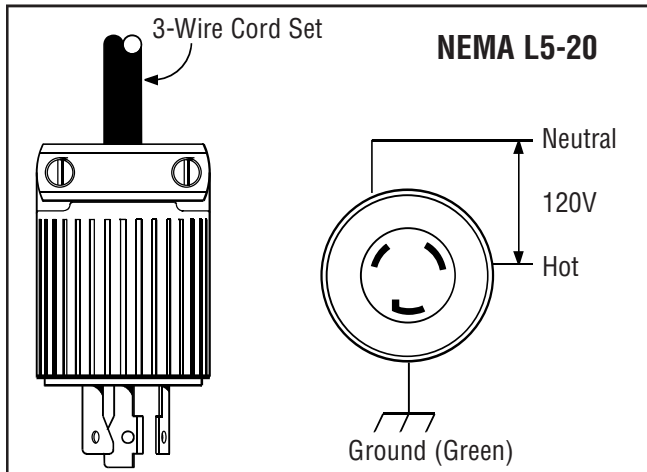

Use this receptacle to operate 120 Volt AC, 60 Hz, single phase loads requiring up to 2,400 watts (2.4 kW) of power at 20 Amps. The outlet is protected by a push-to-reset circuit breaker.

120 Volt AC, 20 Amp, Duplex Receptacles

The duplex receptacle is protected against overload by a push-to-reset circuit breaker.

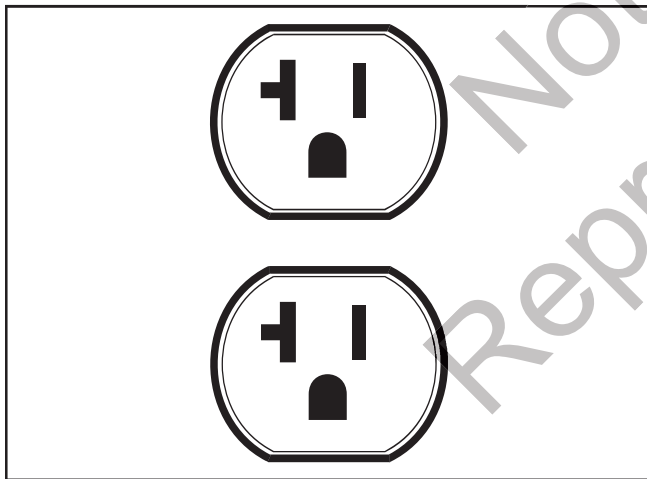

Use each receptacle to operate 120 Volt AC, single-phase, 60 Hz electrical loads requiring up to 2,400 watts (2.4 kW) at 20 Amps of current. Use cord sets that are rated for 125 Volt AC loads at 20 Amps (or greater).

12 Volt DC, 10 Amp Receptacle

This receptacle allows you to recharge a 12 Volt automotive or utility style storage battery with the battery charge cables provided.

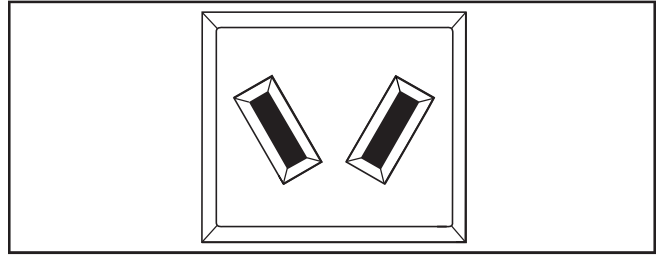

This receptacle can not recharge 6 Volt batteries and can not be used to crank an engine having a discharged battery. See the section *Charging a Battery* before attempting to recharge a battery.

Battery Charger

Use battery float charger jack to keep the starting battery charged and ready for use. Battery charging should be done in a dry location, such as inside a garage.

1. Plug charger into unit's "Battery Float Charger" jack, which is located next to the start switch. Plug battery charger into a 120 Volt AC wall receptacle.

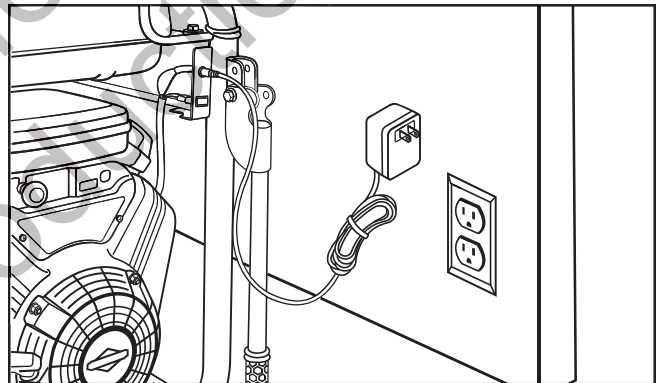

2. Unplug charger from unit and wall outlet when generator is being started and while it is in operation.
3. Keep this charger plugged in when generator is not in use to prolong battery life. The charger has a built in float equalizer and will not overcharge the battery, even when plugged in for an extended period of time.

NOTICE See *Battery Maintenance* for additional information.

Operation

Starting the Engine

NOTICE Always unplug the battery float charger before starting the generator.

Disconnect all electrical loads from the generator. Use the following start instructions:

1. Make sure unit is on a level surface.

NOTICE Failure to start and operate the unit on a level surface will cause the unit not to start or shut down during operation.

2. Turn the fuel valve (A) to the "On" position.

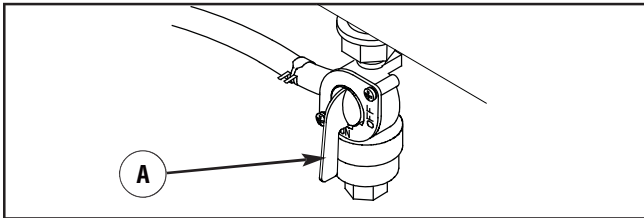

3. Make sure idle control switch is in "Off" position.

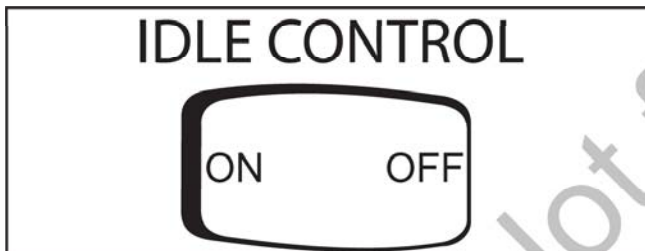

4. Set run/stop switch to "Run" position.

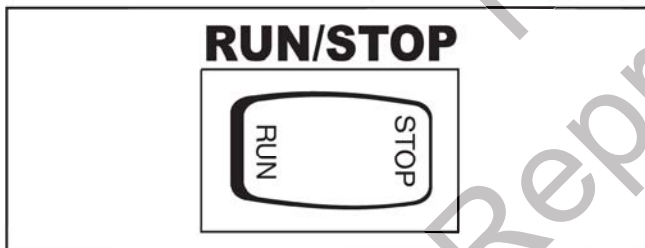

5. Pull choke control out to close choke.

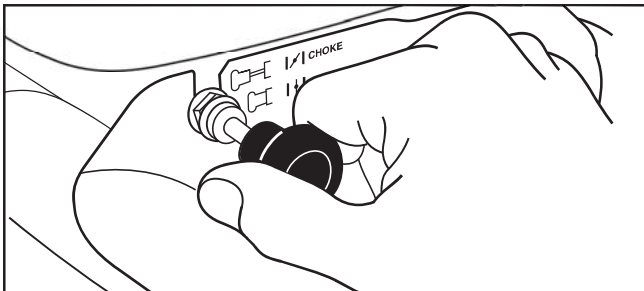

- 6A. **For electric starting**, push and hold the start switch in "Start" position until generator starts. To prolong the life of starter components, DO NOT hold start switch in "Start" position for more than 15 seconds, and pause for at least 1 minute between starting attempts.

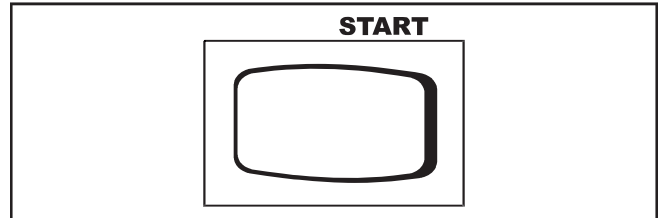

- If engine starts, proceed to step 8.
- If engine fails to start, proceed to step 7.

NOTICE If battery is discharged, use manual starting instructions.

- 6B. **For manual starting**, grasp recoil handle and pull slowly until slight resistance is felt. Then pull rapidly one time only to start engine.

- If engine starts, proceed to step 8.
- If engine fails to start, proceed to step 7.

▲ WARNING Starter cord kickback (rapid retraction) will pull hand and arm toward engine faster than you can let go which could cause broken bones, fractures, bruises, or sprains resulting in serious injury.

- When starting engine, pull cord slowly until resistance is felt and then pull rapidly to avoid kickback.
- NEVER start or stop engine with electrical devices plugged in and turned on.

7. Push in the choke handle half way, and pull recoil handle twice or push and hold the start switch in the "Start" position as described in step 6A.

- If engine fails to start, repeat steps 5 thru 6.

8. Open the choke gradually as the engine warms up by pushing in on the choke handle.

NOTICE If engine floods, place push choke handle all the way in and crank until engine starts.

NOTICE If engine starts after 3 pulls but fails to run, or if unit shuts down during operation, make sure unit is on a level surface and check for proper oil level in crankcase. This unit may be equipped with a low oil protection device. If so, oil must be at proper level for engine to start.

▲ WARNING Exhaust heat/gases could ignite combustibles, structures or damage fuel tank causing a fire, resulting in death, serious injury and/or property damage.



Contact with muffler area could cause burns resulting in serious injury.

- DO NOT touch hot parts and AVOID hot exhaust gases.
 - Allow equipment to cool before touching.
 - Keep at least 5 feet (1.5 m) of clearance on all sides of generator including overhead.
 - It is a violation of California Public Resource Code, Section 4442, to use or operate the engine on any forest-covered, brush-covered, or grass-covered land unless the exhaust system is equipped with a spark arrester, as defined in Section 4442, maintained in effective working order. Other states or federal jurisdictions may have similar laws.
- Contact the original equipment manufacturer, retailer, or dealer to obtain a spark arrester designed for the exhaust system installed on this engine.
- Replacement parts must be the same and installed in the same position as the original parts.

Connecting Electrical Loads

1. Let engine stabilize and warm up for a few minutes after starting.
2. Plug in and turn on the desired 120 and/or 240 Volt AC, single phase, 60 Hz electrical loads.

NOTICE

- DO NOT connect 240 Volt loads to the 120 Volt duplex receptacles.
- DO NOT connect 3-phase loads to the generator.
- DO NOT connect 50 Hz loads to the generator.
- DO NOT OVERLOAD THE GENERATOR. See *Don't Overload Generator*.

NOTICE Exceeding generators wattage/amperage capacity could damage generator and/or electrical devices connected to it.

- DO NOT exceed the generator's wattage/amperage capacity. See *Don't Overload Generator* in the *Operation* section.
- Start generator and let engine stabilize before connecting electrical loads.
- Connect electrical loads in OFF position, then turn ON for operation.
- Turn electrical loads OFF and disconnect from generator before stopping generator.

Stopping the Engine

1. Turn OFF and unplug **all** electrical loads from generator panel receptacles. NEVER start or stop engine with electrical devices plugged in and turned ON.
2. Move idle control switch to "**Off**" position.
3. Let engine run at no-load for several minutes to stabilize internal temperatures of engine and generator.
4. Push run/stop switch to "**Stop**" position.

▲ WARNING Fuel and its vapors are extremely flammable and explosive which could cause burns, fire or explosion resulting in death, serious injury and/or property damage.



- DO NOT stop engine by moving choke control to choke (|X|) position.

5. Move fuel valve to "**Off**" position.

Operating Automatic Idle Control

This feature is designed to greatly improve fuel economy.

When this switch is turned ON, the engine will only run at its normal high governed engine speed when electrical loads are connected. When electrical loads are removed, the engine will run at a reduced speed.

With the switch off, the engine will run at the normal high engine speed. **Always have the switch off when starting and stopping the engine.**

Oil Pressure Shutdown

If engine oil pressure drops below a preset level, an oil switch will stop the engine. Check oil level with dipstick.

If oil level is between ADD and FULL mark on dipstick:

1. DO NOT try to restart the engine.
2. Contact an Authorized Briggs & Stratton Service Dealer.
3. DO NOT operate engine until oil pressure is corrected.

If oil level is below ADD mark on dipstick:

1. Add oil to bring level to FULL mark.
2. Restart engine and if the engine stops again a low oil pressure condition may still exist. DO NOT try to restart the engine.
3. Contact an Authorized Briggs & Stratton Service Dealer.
4. DO NOT operate engine until oil pressure is corrected.

Charging a Battery

Your generator has the capability of recharging a discharged 12 Volt automotive or utility style storage battery.

- DO NOT use the unit to charge any 6 Volt batteries.
- DO NOT use the unit to crank an engine having a discharged battery.

▲ WARNING Storage batteries give off explosive hydrogen gas during recharging. Hydrogen gas stays near battery for a long time after battery has been charged. Slightest spark could ignite hydrogen causing explosion resulting in death, serious injury and/or property damage. Battery electrolyte fluid contains acid and is extremely caustic. Contact with battery fluid could cause chemical burns resulting in serious injury and/or property damage.

▲ WARNING Battery posts, terminals and related accessories contain lead and lead compounds - chemicals known to the State of California to cause cancer and reproductive harm. Wash hands after handling.

- DO NOT allow any open flame, spark, heat, or lit cigarette during and for several minutes after charging a battery.
- Wear protective goggles, rubber apron, and rubber gloves.
- DO NOT continue to charge a battery that becomes hot or is fully charged.
- DO NOT leave battery unattended.

To recharge 12 Volt batteries, proceed as follows:

1. Check fluid level in all battery cells. If necessary, add **ONLY** distilled water to cover separators in battery cells. **DO NOT use tap water.**

▲ WARNING Battery posts, terminals and related accessories contain lead and lead compounds - chemicals known to the State of California to cause cancer and reproductive harm. Wash hands after handling.

2. If battery is equipped with vent caps, make sure they are installed and are tight.
3. If necessary, clean battery terminals.
4. Connect battery charge cable connector plug to panel receptacle identified by the words "12V 10A D.C."

5. Connect battery charge cable clamp with **red** handle to the **positive (+)** battery terminal.

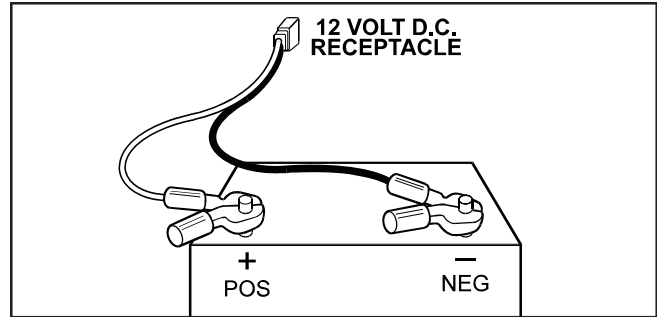

6. Connect battery charge cable clamp with **black** handle to the **negative (-)** battery terminal.
7. Start engine. Let engine run while battery recharges.
8. When battery has charged, shut down engine

NOTICE Use an automotive hydrometer to test battery state of charge and condition. Follow the hydrometer manufacturer's instructions carefully. Generally, a battery is considered to be at 100% state of charge when specific gravity of its fluid (as measured by hydrometer) is 1.260 or higher.

Cold Weather Operation

Under certain weather conditions (temperatures below 40°F [4°C] combined with high humidity), your generator may experience icing of the carburetor and/or the crankcase breather system. To reduce this problem, you need to perform the following:

1. Make sure generator has clean, fresh fuel.
2. Open fuel valve (turn valve to open position).
3. Use SAE 5W-30 oil.
4. Check oil level daily or after every eight (8) hours of operation.
5. Maintain generator following *Maintenance Schedule* in *Maintenance* section.
6. Shelter unit from elements.

Creating a Temporary Cold Weather Shelter

1. For temporary shelter, the original shipping carton can be used.
2. Cut off top carton flaps and one long side of carton to expose muffler side of unit. If required, tape up other sides of carton to fit over generator as shown.

NOTICE If required, remove wheel kit to fit carton over generator as shown.

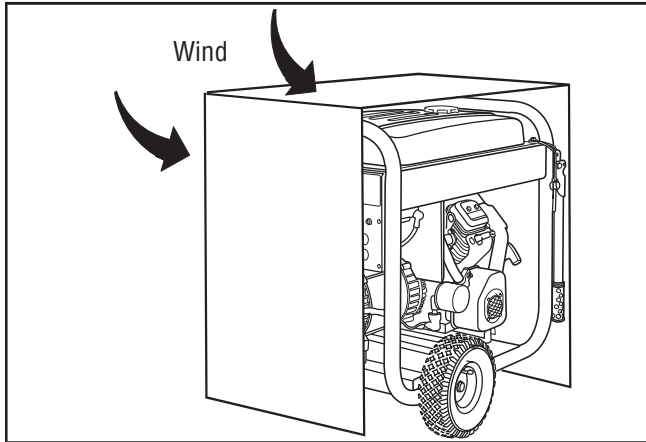

3. Cut appropriate slots to access receptacles of unit.
4. Face exposed end away from wind and elements.
5. Locate generator as described in the section *Generator Location*. Keep exhaust gas from entering a confined area through windows, doors, ventilation intakes or other openings.

- ▲ WARNING** Running engine gives off carbon monoxide, an odorless, colorless, poison gas. Breathing carbon monoxide could result in death, serious injury, headache, fatigue, dizziness, vomiting, confusion, seizures, nausea or fainting.
- Operate this product **ONLY** outdoors.
 - Install a battery operated carbon monoxide alarm near the bedrooms.
 - Keep exhaust gas from entering a confined area through windows, doors, ventilation intakes, or other openings.
 - **DO NOT** operate this product inside any building, carport, porch, mobile equipment, marine applications, or enclosure, even if windows and doors are open.

6. Start generator as described in the section *Starting the Engine*, then place carton over generator. Keep at least 5 ft. (1.5 m) clearance on all sides of generator including overhead with shelter in place.

▲ WARNING Exhaust heat/gases could ignite combustibles, structures or damage fuel tank causing a fire, resulting in death, serious injury and/or property damage.

Contact with muffler area could cause burns resulting in serious injury.

- **DO NOT** touch hot parts and **AVOID** hot exhaust gases.
- Allow equipment to cool before touching.
- Keep at least 5 feet (1.5 m) of clearance on all sides of generator including overhead.
- Remove shelter when temperatures are above 40°F [4°C].

7. Remove shelter when temperatures are above 40°F [4°C].
8. Turn engine **OFF** and let cool two (2) minutes before refueling. Let any spilled fuel evaporate before starting engine.

Building a Cold Weather Shelter

1. Using non combustible material with a fire rating of at least one hour, build a shelter that will enclose three sides and the top of the generator. Make sure muffler side of generator is exposed.

NOTICE Contact your local building material supplier for non combustible materials with a fire rating of at least one hour.

NOTICE Be sure shelter can easily be repositioned for change in wind direction.

2. **DO NOT** enclose generator any more than shown. Shelter should hold enough heat created by the generator to prevent icing problem.

NOTICE If a wheel kit is installed on the generator, enlarge shelter accordingly.

3. Follow steps 3 through 8 as described previously in *Creating a Temporary Cold Weather Shelter*.

Don't Overload Generator

Capacity

You must make sure your generator can supply enough rated (running) and surge (starting) watts for the items you will power at the same time. Follow these simple steps:

1. Select the items you will power at the same time.
2. Total the rated (running) watts of these items. This is the amount of power your generator must produce to keep your items running. See the table on the right.
3. Estimate how many surge (starting) watts you will need. Surge wattage is the short burst of power needed to start electric motor-driven tools or appliances such as a circular saw or refrigerator. Because not all motors start at the same time, total surge watts can be estimated by adding only the item(s) with the highest additional surge watts to the total rated watts from step 2.

Example:

Tool or Appliance	Watts	(Starting) Watts
Window Air Conditioner	1200	1800
Refrigerator	800	1600
Deep Freezer	500	500
Television	500	—
Light (75 Watts)	75	—
	3075 Total Running Watts	1800 Highest Surge Watts

Total Rated (Running) Watts = 3075
 Highest Additional Surge Watts = 1800
 Total Generator Output Required = 4875

Power Management

To prolong the life of your generator and attached devices, it is important to take care when adding electrical loads to your generator. There should be nothing connected to the generator outlets before starting its engine. The correct and safe way to manage generator power is to sequentially add loads as follows:

1. With nothing connected to the generator, start the engine as described in this manual.
2. Plug in and turn on the first load, preferably the largest load you have.
3. Permit the generator output to stabilize (engine runs smoothly and attached device operates properly).
4. Plug in and turn on the next load.
5. Again, permit the generator to stabilize.
6. Repeat steps 4 and 5 for each additional load.

Tool or Appliance	Rated* (Running) Watts	Additional Surge (Starting) Watts
Essentials		
Light Bulb - 75 watt	75	-
Deep Freezer	500	500
Sump Pump	800	1200
Refrigerator/Freezer - 18 Cu. Ft.	800	1600
Water Well Pump - 1/3 HP	1000	2000
Heating/Cooling		
Window AC - 10,000 BTU	1200	1800
Window Fan	300	600
Furnace Fan Blower - 1/2 HP	800	1300
Kitchen		
Microwave Oven - 1000 Watt	1000	-
Coffee Maker	1500	-
Electric Stove - Single Element	1500	-
Hot Plate	2500	-
Family Room		
DVD/CD Player	100	-
VCR	100	-
Stereo Receiver	450	-
Color Television - 27"	500	-
Personal Computer w/17" monitor	800	-
Other		
Security System	180	-
AM/FM Clock Radio	300	-
Garage Door Opener - 1/2 HP	480	520
Electric Water Heater - 40 Gallon	4000	-
DIY/Job Site		
Quartz Halogen Work Light	1000	-
Airless Sprayer - 1/3 HP	600	1200
Reciprocating Saw	960	960
Electric Drill - 1/2 HP	1000	1000
Circular Saw - 7 1/4"	1500	1500
Miter Saw - 10"	1800	1800
Table Planer - 6"	1800	1800
Table Saw/Radial Arm Saw - 10"	2000	2000
Air Compressor - 1-1/2 HP	2500	2500

NEVER add more loads than the generator capacity. Take special care to consider surge loads in generator capacity, as described above.

* Wattages listed are approximate only. Check tool or appliance for actual wattage.

Maintenance

Maintenance Schedule

Follow the hourly or calendar intervals, whichever occurs first. More frequent service is required when operating in adverse conditions noted below.

First 8 Hours
<ul style="list-style-type: none">• Change engine oil
Every 8 Hours or Daily
<ul style="list-style-type: none">• Clean debris• Check engine oil level
Every 25 Hours or Yearly
<ul style="list-style-type: none">• Service engine air cleaner pre-filter¹
Every 50 Hours or Yearly
<ul style="list-style-type: none">• Inspect muffler and spark arrester
Every 100 Hours or Yearly
<ul style="list-style-type: none">• Change engine oil and filter²• Service air cleaner paper filter¹• Service fuel filter• Service spark plugs• Clean cooling system¹
Every 250 Hours or Yearly
<ul style="list-style-type: none">• Check valve clearance

¹ Service more often under dirty or dusty conditions.

² Change oil every 50 hours or every season, whichever occurs first, if operating under heavy load or high ambient temperature.

General Recommendations

Regular maintenance will improve the performance and extend the life of the generator. See any authorized dealer for service.

The generator's warranty does not cover items that have been subjected to operator abuse or negligence. To receive full value from the warranty, the operator must maintain the generator as instructed in this manual.

Some adjustments will need to be made periodically to properly maintain your generator.

All service and adjustments should be made at least once each season. Follow the requirements in the Maintenance Schedule chart above.

NOTICE Once a year you should clean or replace the spark plug and replace the air filter. New spark plugs and clean air filter assure proper fuel-air mixture and help your engine run better and last longer.

Emissions Control

Maintenance, replacement, or repair of the emissions control devices and systems may be performed by any non-road engine repair establishment or individual.

However, to obtain "no charge" emissions control service, the work must be performed by a factory authorized dealer. See the *Emissions Warranty*.

Generator Maintenance

Generator maintenance consists of keeping the unit clean and dry. Operate and store the unit in a clean dry environment where it will not be exposed to excessive dust, dirt, moisture, or any corrosive vapors. Cooling air slots in the generator must not become clogged with snow, leaves, or any other foreign material.

NOTICE DO NOT use water or other liquids to clean generator. Liquids can enter engine fuel system, causing poor performance and/or failure to occur. In addition, if liquid enters generator through cooling air slots, some of the liquid will be retained in voids and cracks of the rotor and stator winding insulation. Liquid and dirt buildup on the generator internal windings will eventually decrease the insulation resistance of these windings.

Cleaning

Daily or before use, look around and underneath the generator for signs of oil or fuel leaks. Clean accumulated debris from inside and outside the generator. Keep the linkage, spring and other engine controls clean. Keep the area around and behind the muffler free from any combustible debris. Inspect cooling air slots and openings on generator. These openings must be kept clean and unobstructed.

Engine parts should be kept clean to reduce the risk of overheating and ignition of accumulated debris:

- Use a damp cloth to wipe exterior surfaces clean.

NOTICE Improper treatment of generator could damage it and shorten its life.

- DO NOT expose generator to excessive moisture, dust, dirt, or corrosive vapors.
- DO NOT insert any objects through cooling slots.

- Use a soft bristle brush to loosen caked on dirt or oil.
- Use a vacuum cleaner to pick up loose dirt and debris.

Battery Maintenance

Other than float charging, described elsewhere, no maintenance is required for the starting battery. Keep the battery and terminals clean and dry.

NOTICE Battery charging should be performed in a dry location, such as inside a garage.

▲ WARNING Battery posts, terminals and related accessories contain lead and lead compounds - chemicals known to the State of California to cause cancer and reproductive harm. Wash hands after handling.

Fuel Valve Maintenance

The fuel valve is equipped with a fuel sediment cup, screen, retaining ring and o-ring that need to be cleaned every 100 hours or once a year (whichever occurs first).

1. Move fuel valve to “Off” position.
2. Remove sediment cup (A) from fuel valve. Remove o-ring (B), retaining ring (C) and screen (D) from fuel valve.

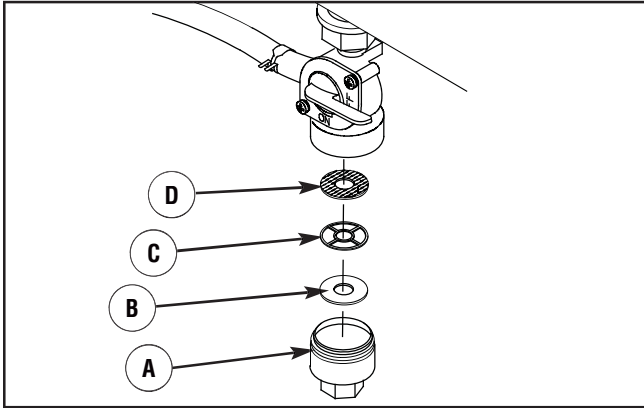

3. Wash sediment cup, o-ring, retaining ring, and screen in a nonflammable solvent. Dry them thoroughly.
4. Place screen, retaining ring, and o-ring into fuel valve. Install sediment cup and tighten securely.
5. Move fuel valve to “On” position, and check for leaks. Replace o-ring if there is any leakage.

Engine Maintenance

WARNING Unintentional sparking could cause fire or electric shock resulting in death or serious injury.



WHEN ADJUSTING OR MAKING REPAIRS TO YOUR GENERATOR

- Disconnect the spark plug wire from the spark plug and place the wire where it cannot contact spark plug.

WHEN TESTING FOR ENGINE SPARK

- Use approved spark plug tester.
- DO NOT check for spark with spark plug removed.

Oil

Oil Recommendations

We recommend the use of Briggs & Stratton Warranty Certified oils for best performance. Other high-quality detergent oils are acceptable if classified for service SF, SG, SH, SJ or higher. DO NOT use special additives.

Outdoor temperatures determine the proper oil viscosity for the engine. Use the chart to select the best viscosity for the outdoor temperature range expected.

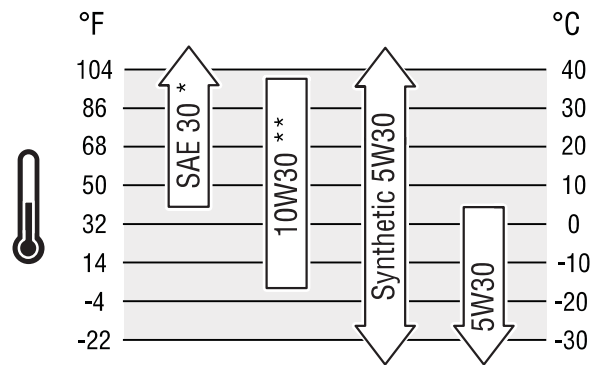

* Below 40°F (4°C) the use of SAE 30 will result in hard starting.

** Above 80°F (27°C) the use of 10W30 may cause increased oil consumption. Check oil level more frequently.

Checking Oil Level

Oil level should be checked prior to each use or at least every 8 hours of operation. Keep oil level maintained.

1. Make sure generator is on a level surface.
2. Clean area around oil dipstick, remove oil dipstick and wipe dipstick with clean cloth. Insert dipstick firmly, then remove and check oil level.
3. Verify oil is at “Full” mark on dipstick. Insert dipstick firmly before starting engine.

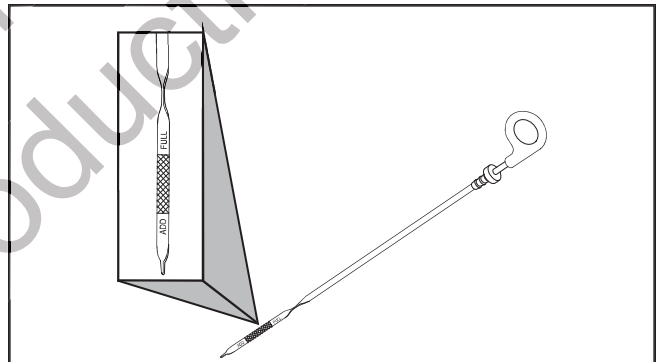

Adding Engine Oil

1. Make sure generator is on a level surface.
2. Check oil level as described in *Checking Oil Level*.
3. If needed, remove oil fill cap and slowly pour oil into oil fill opening to the “Full” mark on dipstick. DO NOT overfill.

NOTICE Overfilling with oil could cause the engine to not start, or hard starting.

- DO NOT overfill.
 - If over the FULL mark on dipstick, drain oil to reduce oil level to FULL mark on dipstick.
4. Replace and tighten both the oil fill cap and dipstick.

Changing Engine Oil and Filter

If you are using your generator under heavy load, or in extremely hot weather, change the oil every 50 hours.

CAUTION Avoid prolonged or repeated skin contact with used motor oil.

- Used motor oil has been shown to cause skin cancer in certain laboratory animals.
- Thoroughly wash exposed areas with soap and water.



KEEP OUT OF REACH OF CHILDREN. DON'T POLLUTE. CONSERVE RESOURCES. RETURN USED OIL TO COLLECTION CENTERS.

Change the oil while the engine is still warm from running, as follows:

1. Make sure unit is on a level surface.
2. Disconnect the spark plug wires from the spark plug and place the wire where it cannot contact spark plugs.
3. Clean area around oil drain plug. The oil drain plug is located at base of engine.
4. Remove oil drain plug and oil fill cap and drain oil completely into a suitable container.
5. Reinstall oil drain plug and tighten securely.
6. Place a suitable container beneath oil filter and turn filter counterclockwise to remove.
7. Lightly coat gasket of a new filter with fresh engine oil. Turn new filter clockwise until gasket contacts filter adapter, then tighten an additional 3/4 turn.
8. Remove oil dipstick.
9. Slowly pour 32 oz. (1 liter) of recommended oil into oil fill opening.
10. Start and run engine for 30 seconds. Shut engine off and wait 30 seconds for oil to settle.
11. Add more oil to "Full" mark on dipstick. Wipe dipstick clean each time oil level is checked. DO NOT overfill.

NOTICE Engine holds approximately 48 oz. (1.4 liters) when changing oil and filter.

12. Reinstall oil fill cap and oil dipstick. Tighten oil fill cap securely.
13. Wipe up any spilled oil.
14. Reconnect spark plug wires to spark plugs.

Service Air Cleaner

Your engine will not run properly and may be damaged if you run it with a dirty air cleaner. Clean or replace more often if operating under dusty or dirty conditions.

To service the air cleaner, follow these steps:

1. Unhook latches (A) on both sides of cover (B) and remove cover.
2. Remove knob (C) and plate (D). Carefully remove air cleaner assembly to prevent debris from entering carburetor.

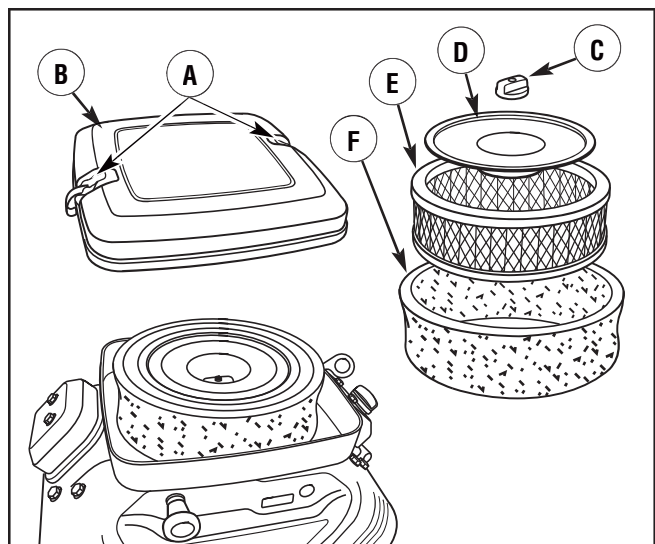

3. Slide foam pre-cleaner (F) off cartridge (E) and wash pre-cleaner in liquid detergent and water.
4. Squeeze the pre-cleaner dry with a clean cloth. DO NOT TWIST.
5. Tap cartridge gently on a solid surface to loosen and remove trapped particles.
6. Reassemble clean (or new) pre-cleaner on clean (or new) cartridge.
7. Install clean (or new) air cleaner assembly inside cover. Dispose of old filter properly.
8. Reinstall knob and plate.
9. Replace cover and reattach latches to cover.

Service Spark Plugs

Changing the spark plugs will help your engine to start easier and run better.

1. Clean area around spark plugs.
2. Remove and inspect spark plugs.
3. Replace spark plugs if electrodes are pitted, burned or porcelain is cracked. Use the recommended replacement spark plugs. See *Specifications*.
4. Check electrode gap with wire feeler gauge and reset spark plug gap to recommended gap if necessary (see *Specifications*).

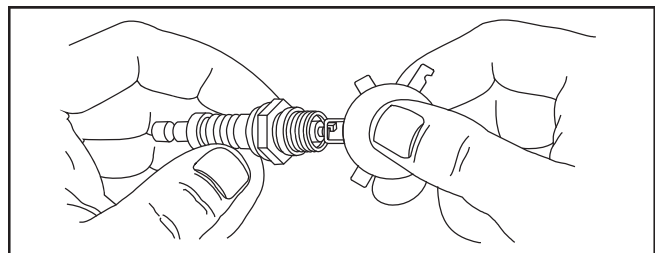

5. Install spark plugs and tighten firmly.

Inspect Muffler and Spark Arrester

Inspect the muffler for cracks, corrosion, or other damage. Remove the spark arrester, if equipped, and inspect for damage or carbon blockage. If replacement parts are required, make sure to use only original equipment replacement parts.

▲ WARNING Exhaust heat/gases could ignite combustibles, structures or damage fuel tank causing a fire, resulting in death, serious injury and/or property damage.



Contact with muffler area could cause burns resulting in serious injury.

- DO NOT touch hot parts and AVOID hot exhaust gases.
- Allow equipment to cool before touching.
- Keep at least 5 feet (152 cm) of clearance on all sides of generator including overhead.
- It is a violation of California Public Resource Code, Section 4442, to use or operate the engine on any forest-covered, brush-covered, or grass-covered land unless the exhaust system is equipped with a spark arrester, as defined in Section 4442, maintained in effective working order. Other states or federal jurisdictions may have similar laws.

Contact the original equipment manufacturer, retailer, or dealer to obtain a spark arrester designed for the exhaust system installed on this engine.

- Replacement parts must be the same and installed in the same position as the original parts.

Clean and inspect the spark arrester as follows:

1. Remove four screws that attach the spark arrester screen.

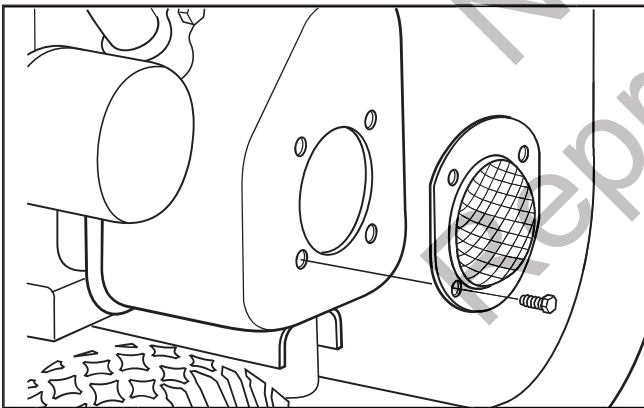

2. Inspect screen and replace if torn, perforated or otherwise damaged. DO NOT USE a defective screen. If screen is not damaged, clean it with commercial solvent.
3. Reattach the screen with four screws.

Clean Cooling System

Over time debris may accumulate in cylinder cooling fins and cannot be observed without partial engine disassembly. For this reason, we recommend you have an authorized service dealer clean the cooling system per recommended intervals (see *Maintenance Schedule* in the *Maintenance* section). Equally important is to keep top of engine free from debris. Also see *Cleaning*.

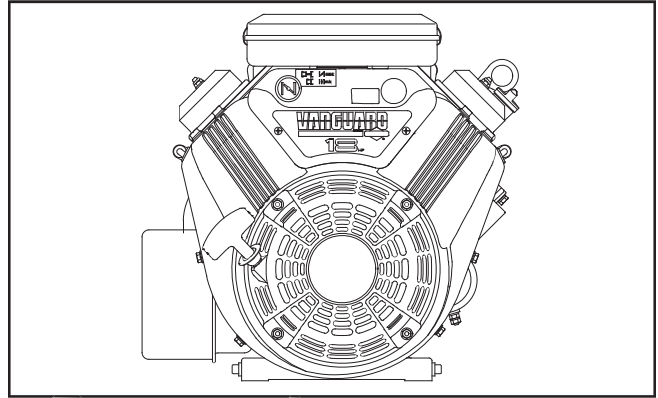

Check Valve Clearance

Regular valve clearance check and adjustment will improve performance and extend engine life. This procedure cannot be done without partial engine disassembly and the use of special tools. For this reason we recommend that you have an authorized Service Dealer check and adjust valve clearance at recommended intervals (see *Maintenance Schedule* in the *Maintenance* section).

Carburetor Adjustment

The carburetor on this engine is low emission. It is equipped with a non-adjustable idle mixture valve. Top speed has been set at the factory. If adjustment is required, see an authorized service dealer.

▲ CAUTION Excessively high operating speeds could result in minor injury and/or generator damage. Excessively low speeds impose a heavy load.

- DO NOT tamper with governor spring, links or other parts to increase engine speed. Generator supplies correct rated frequency and voltage when running at governed speed.
- DO NOT modify generator in any way.

Storage

The generator should be started at least once every seven days and allowed to run at least 30 minutes. If this cannot be done and you must store the unit for more than 30 days, use the following guidelines to prepare it for storage.

Generator Storage

- Clean the generator as outlined in *Cleaning* in the *Maintenance* section.
- Check that cooling air slots and openings on generator are open and unobstructed.

Long Term Storage Instructions

Fuel can become stale when stored over 30 days. Stale fuel causes acid and gum deposits to form in the fuel system or on essential carburetor parts. To keep fuel fresh, use Briggs & Stratton® Advanced Formula Fuel Treatment & Stabilizer, available wherever Briggs & Stratton genuine service parts are sold.

For engines equipped with a FRESH START® fuel cap, use Briggs & Stratton FRESH START® available in a drip concentrate cartridge.

There is no need to drain gasoline from the engine if a fuel stabilizer is added according to instructions. Run the engine for 2 minutes to circulate the stabilizer throughout the fuel system before storage.

If gasoline in the engine has not been treated with a fuel stabilizer, it must be drained into an approved container. Run the engine until it stops from lack of fuel. The use of a fuel stabilizer in the storage container is recommended to maintain freshness.

 **WARNING** Fuel and its vapors are extremely flammable and explosive which could cause burns, fire or explosion resulting in death, serious injury and/or property damage.

WHEN STORING FUEL OR EQUIPMENT WITH FUEL IN TANK

- Store away from furnaces, stoves, water heaters, clothes dryers or other appliances that have pilot light or other ignition source because they could ignite fuel vapors.

WHEN DRAINING FUEL

- Turn generator engine OFF and let it cool at least 2 minutes before removing fuel cap. Loosen cap slowly to relieve pressure in tank.
- Drain fuel tank outdoors.
- Keep fuel away from sparks, open flames, pilot lights, heat, and other ignition sources.
- Check fuel lines, tank, cap and fittings frequently for cracks or leaks. Replace if necessary.
- DO NOT light a cigarette or smoke.

Change Oil

While engine is still warm, drain oil from crankcase. Refill with recommended grade. See *Changing Engine Oil* in *Maintenance*.

Other Storage Tips

1. DO NOT store fuel from one season to another unless it has been treated as described in *Protect Fuel System*.
2. Replace fuel can if it starts to rust. Contaminated fuel will cause engine problems.
3. If possible, store unit indoors and cover it to give protection from dust and dirt.
4. Cover unit with a suitable protective cover that does not retain moisture.

 **WARNING** Storage covers could cause a fire resulting in death, serious injury and/or property damage.

- DO NOT place a storage cover over a hot generator.
- Let equipment cool for a sufficient time before placing the cover on the equipment.

5. Store generator in clean, dry area.

Troubleshooting

Problem	Cause	Correction
Engine is running, but no AC output is available.	<ol style="list-style-type: none"> 1. One of the circuit breakers is open. 2. Fault in generator. 3. Poor connection or defective cord set. 4. Connected device is bad. 	<ol style="list-style-type: none"> 1. Reset circuit breaker. 2. Contact authorized service facility. 3. Check and repair. 4. Connect another device that is in good condition.
Engine runs good at no-load but "bogs down" when loads are connected.	<ol style="list-style-type: none"> 1. Short circuit in a connected load. 2. Engine speed is too slow. 3. Generator is overloaded. 4. Shorted generator circuit. 5. Clogged or dirty fuel filter. 	<ol style="list-style-type: none"> 1. Disconnect shorted electrical load. 2. Contact authorized service facility. 3. See <i>Don't Overload Generator</i>. 4. Contact authorized service facility. 5. Clean or replace fuel filter.
Engine will not start; starts and runs rough or shuts down when running.	<ol style="list-style-type: none"> 1. Run/Stop switch set to "Stop". 2. Fuel valve is in "Off" position. 3. Failed battery. 4. Low oil level. 5. Dirty air cleaner. 6. Clogged or dirty fuel filter. 7. Out of fuel. 8. Stale fuel. 9. Spark plug wire not connected to spark plug. 10. Bad spark plug. 11. Water in fuel. 12. Flooded. 13. Excessively rich fuel mixture. 14. Intake valve stuck open or closed. 15. Engine has lost compression. 	<ol style="list-style-type: none"> 1. Set switch to "Run". 2. Turn fuel valve to "On" position. 3. Replace battery. 4. Fill crankcase to proper level or place generator on level surface. 5. Clean or replace air cleaner. 6. Clean or replace fuel filter. 7. Fill fuel tank. 8. Drain fuel tank and carburetor; fill with fresh fuel. 9. Connect wire to spark plug. 10. Replace spark plug. 11. Drain fuel tank and carburetor; fill with fresh fuel. 12. Wait 5 minutes and re-crank engine. 13. Contact authorized service facility. 14. Contact authorized service facility. 15. Contact authorized service facility.
Engine lacks power.	<ol style="list-style-type: none"> 1. Load is too high. 2. Dirty air filter. 3. Clogged or dirty fuel filter. 	<ol style="list-style-type: none"> 1. See <i>Don't Overload Generator</i>. 2. Replace air filter. 3. Clean or replace fuel filter.
Engine "hunts" or falters.	<ol style="list-style-type: none"> 1. Carburetor is running too rich or too lean. 2. Clogged or dirty fuel filter. 	<ol style="list-style-type: none"> 1. Contact authorized service facility. 2. Clean or replace fuel filter.

Warranties

California, U.S. EPA, and Briggs & Stratton Corporation Emissions Control Warranty Statement

Your Warranty Rights And Obligations

The California Air Resources Board, U.S. EPA, and Briggs & Stratton (B&S) are pleased to explain the emissions control system warranty on your Model Year 2011-2012 engine/equipment. In California, new small off-road engines and large spark ignited engines less than or equal to 1.0 liter must be designed, built, and equipped to meet the State's stringent anti-smog standards. B&S must warrant the emissions control system on your engine/equipment for the periods of time listed below provided there has been no abuse, neglect, or improper maintenance of your engine or equipment.

Your emissions control system may include parts such as the carburetor or fuel injection system, fuel tank, ignition system, and catalytic converter. Also included may be hoses, belts, connectors, sensors, and other emissions-related assemblies. Where a warrantable condition exists, B&S will repair your engine/equipment at no cost to you including diagnosis, parts, and labor.

Manufacturer's Warranty Coverage:

Small off-road engines and large spark ignited engines less than or equal to 1.0 liter are warranted for two years. If any emissions-related part on your engine/equipment is defective, the part will be repaired or replaced by B&S.

Owner's Warranty Responsibilities:

- As the engine/equipment owner, you are responsible for the performance of the required maintenance listed in your owner's manual. B&S recommends that you retain all receipts covering maintenance on your engine/equipment, but B&S cannot deny warranty solely for the lack of receipts or your failure to ensure the performance of all scheduled maintenance.
- As the engine/equipment owner, you should however be aware that B&S may deny you warranty coverage if your engine/equipment or a part has failed due to abuse, neglect, improper maintenance, or unapproved modifications.
- You are responsible for presenting your engine/equipment to a B&S distribution center, servicing dealer, or other equivalent entity, as applicable, as soon as a problem exists. The warranty repairs should be completed in a reasonable amount of time, not to exceed 30 days. If you have any questions regarding your warranty rights and responsibilities, you should contact B&S at (414) 259-5262.

Briggs & Stratton Emissions Control Warranty Provisions

The following are specific provisions relative to your Emissions Control Warranty Coverage. It is in addition to the B&S engine warranty for non-regulated engines found in the Operator's Manual.

1. Warranted Emissions Parts

Coverage under this warranty extends only to the parts listed below (the emissions control systems parts) to the extent these parts were present on the B&S engine and/or B&S supplied fuel system.

a. Fuel Metering System

- Cold start enrichment system (soft choke)
- Carburetor and internal parts
- Fuel pump
- Fuel line, fuel line fittings, clamps
- Fuel tank, cap and tether
- Carbon canister

b. Air Induction System

- Air cleaner
- Intake manifold
- Purge and vent line

c. Ignition System

- Spark plug(s)
- Magneto ignition system

d. Catalyst System

- Catalytic converter
- Exhaust manifold
- Air injection system or pulse valve

e. Miscellaneous Items Used in Above Systems

- Vacuum, temperature, position, time sensitive valves and switches
- Connectors and assemblies

2. Length of Coverage

For a period of two years from date of original purchase, B&S warrants to the original purchaser and each subsequent purchaser that the engine is designed, built, and equipped so as to conform with all applicable regulations adopted by the Air Resources Board; that it is free from defects in material and workmanship that could cause the failure of a warranted part; and that it is identical in all material respects to the engine described in the manufacturer's application for certification. The warranty period begins on the date the engine is originally purchased.

The warranty on emissions-related parts is as follows:

- Any warranted part that is not scheduled for replacement as required maintenance in the owner's manual supplied, is warranted for the warranty period stated above. If any such part fails during the period of warranty coverage, the part will be repaired or replaced by B&S at no charge to the owner. Any such part repaired or replaced under the warranty will be warranted for the remaining warranty period.
 - Any warranted part that is scheduled only for regular inspection in the owner's manual supplied, is warranted for the warranty period stated above. Any such part repaired or replaced under warranty will be warranted for the remaining warranty period.
 - Any warranted part that is scheduled for replacement as required maintenance in the owner's manual supplied, is warranted for the period of time prior to the first scheduled replacement point for that part. If the part fails prior to the first scheduled replacement, the part will be repaired or replaced by B&S at no charge to the owner. Any such part repaired or replaced under warranty will be warranted for the remainder of the period prior to the first scheduled replacement point for the part.
 - Add on or modified parts that are not exempted by the Air Resources Board may not be used. The use of any non exempted add on or modified parts by the owner will be grounds for disallowing a warranty claim. The manufacturer will not be liable to warrant failures of warranted parts caused by the use of a non exempted add on or modified part.
3. Consequential Coverage
Coverage shall extend to the failure of any engine components caused by the failure of any warranted emissions parts.
4. Claims and Coverage Exclusions
Warranty claims shall be filed according to the provisions of the B&S engine warranty policy. Warranty coverage does not apply to failures of emissions parts that are not original equipment B&S parts or to parts that fail due to abuse, neglect, or improper maintenance as set forth in the B&S engine warranty policy. B&S is not liable for warranty coverage of failures of emissions parts caused by the use of add-on or modified parts.

Look For Relevant Emissions Durability Period and Air Index Information On Your Small Off-Road Engine Emissions Label

Engines that are certified to meet the California Air Resources Board (CARB) small off-road Emissions Standard must display information regarding the Emissions Durability Period and the Air Index. Briggs & Stratton makes this information available to the consumer on our emissions labels. The engine emissions label will indicate certification information.

The **Emissions Durability Period** describes the number of hours of actual running time for which the engine is certified to be emissions compliant, assuming proper maintenance in accordance with the Operating & Maintenance Instructions. The following categories are used:

Moderate:

Engine is certified to be emissions compliant for 125 hours of actual engine running time.

Intermediate:

Engine is certified to be emissions compliant for 250 hours of actual engine running time.

Extended:

Engine is certified to be emissions compliant for 500 hours of actual engine running time.

For example, a typical walk-behind lawn mower is used 20 to 25 hours per year. Therefore, the **Emissions Durability Period** of an engine with an **intermediate** rating would equate to 10 to 12 years. Briggs & Stratton engines are certified to meet the United States Environmental Protection Agency (USEPA) Phase 2 emissions standards. For Phase 2 certified engines, the Emissions Compliance Period referred to on the Emissions Compliance label indicates the number of operating hours for which the engine has been shown to meet Federal emissions requirements.

For engines less than 225 cc displacement.

Category C = 125 hours

Category B = 250 hours

Category A = 500 hours

For engines of 225 cc or more displacement.

Category C = 250 hours

Category B = 500 hours

Category A = 1000 hours

BRIGGS & STRATTON POWER PRODUCTS GROUP, LLC PORTABLE GENERATOR OWNER WARRANTY POLICY

Effective November 1, 2009; replaces all undated Warranties and all Warranties dated before November 1, 2009.

LIMITED WARRANTY

Briggs & Stratton Power Products Group, LLC will repair or replace, free of charge, any part(s) of the portable generator that is defective in material or workmanship or both. Transportation charges on product submitted for repair or replacement under this warranty must be borne by purchaser. This warranty is effective for the time periods and subject to the conditions stated below. For warranty service, find the nearest Authorized Service Dealer in our dealer locator map at BRIGGSandSTRATTON.COM.

THERE IS NO OTHER EXPRESS WARRANTY. IMPLIED WARRANTIES, INCLUDING THOSE OF MERCHANTABILITY AND FITNESS FOR A PARTICULAR PURPOSE, ARE LIMITED TO ONE YEAR FROM PURCHASE, OR TO THE EXTENT PERMITTED BY LAW. ANY AND ALL IMPLIED WARRANTIES ARE EXCLUDED. LIABILITY FOR INCIDENTAL OR CONSEQUENTIAL DAMAGES ARE EXCLUDED TO THE EXTENT EXCLUSION IS PERMITTED BY LAW. Some states or countries do not allow limitations on how long an implied warranty lasts, and some states or countries do not allow the exclusion or limitation of incidental or consequential damages, so the above limitation and exclusion may not apply to you. This warranty gives you specific legal rights and you may also have other rights which vary from state to state or country to country.

WARRANTY PERIOD

Consumer Use	2 years*
Commercial Use	1 year

*Second year parts only

The warranty period begins on the date of purchase by the first retail end user, and continues for the period of time stated above. "Consumer Use" means personal residential household use by a retail consumer. "Commercial Use" means all other uses, including use for commercial, income producing or rental purposes. Once equipment has experienced commercial use, it shall thereafter be considered as commercial use for purposes of this warranty.

NO WARRANTY REGISTRATION IS NECESSARY TO OBTAIN WARRANTY ON BRIGGS & STRATTON PRODUCTS. SAVE YOUR PROOF OF PURCHASE RECEIPT. IF YOU DO NOT PROVIDE PROOF OF THE INITIAL PURCHASE DATE AT THE TIME WARRANTY SERVICE IS REQUESTED, THE MANUFACTURING DATE OF THE PRODUCT WILL BE USED TO DETERMINE THE WARRANTY PERIOD.

ABOUT YOUR WARRANTY

We welcome warranty repair and apologize to you for being inconvenienced. Any Authorized Service Dealer may perform warranty repairs. Most warranty repairs are handled routinely, but sometimes requests for warranty service may not be appropriate. For example, warranty service would not apply if equipment damage occurred because of misuse, lack of routine maintenance, shipping, handling, warehousing or improper installation. Similarly, the warranty is void if the manufacturing date or the serial number on the portable generator has been removed or the equipment has been altered or modified. During the warranty period, the Authorized Service Dealer, at its option, will repair or replace any part that, upon examination, is found to be defective under normal use and service. This warranty will not cover the following repairs and equipment:

- **Normal Wear:** Outdoor Power Equipment, like all mechanical devices, needs periodic parts and service to perform well. This warranty does not cover repair when normal use has exhausted the life of a part or the equipment.
- **Installation and Maintenance:** This warranty does not apply to equipment or parts that have been subjected to improper or unauthorized installation or alteration and modification, misuse, negligence, accident, overloading, overspeeding, improper maintenance, repair or storage so as, in our judgment, to adversely affect its performance and reliability. This warranty also does not cover normal maintenance such as air filters, adjustments, fuel system cleaning and obstruction (due to chemical, dirt, carbon, lime, and so forth).
- **Other Exclusions:** This warranty excludes wear items such as o-rings, filters, etc., or malfunctions resulting from accidents, abuse, modifications, alterations, or improper servicing or freezing or chemical deterioration. Accessory parts such as starting batteries, generator adapter cord sets and storage covers are excluded from the product warranty. This warranty excludes used, reconditioned, and demonstration equipment, equipment used for prime power in place of utility power, equipment used in life support applications, and failures due to acts of God and other force majeure events beyond the manufacturers control. 198189E, Rev. C, 11/2/2009

BRIGGS & STRATTON POWER PRODUCTS GROUP, LLC
MILWAUKEE, WI, USA

Not for
Reproduction



Portable Generator

Product Specifications

Starting Wattage	12,500 Watts
Wattage*	10,000 Watts
AC Voltage	120/240 Volts
at 240 Volts	41.6 Amps
at 120 Volts	83.3 Amps
Frequency	60 Hz at 3600 rpm
Phase	Single Phase
Displacement	34.75 cu. in. (570 cc)
Spark Plug Gap	0.030 in. (0.76 mm)
Fuel Capacity	7 U.S. Gallons (26.5 Liters)
Oil Capacity (with filter)	48 Ounces (1.4 Liters)

Common Service Parts

Air Cleaner w/Pre-Cleaner	5050
Air Cleaner	394018
Pre-Cleaner	272490
Oil Filter	492932 or 5049
Extended Life Oil Filter	696854 or 5076
Resistor Spark Plug	491055
Engine Oil Bottle	100005 or 100028
Synthetic Oil Bottle	100074
Fuel Stabilizer	100120 or 100117
Spark Arrester	392390

Power Ratings: The gross power rating for individual gas engine models is labeled in accordance with SAE (Society of Automotive Engineers) code J1940 (Small Engine Power & Torque Rating Procedure), and rating performance has been obtained and corrected in accordance with SAE J1995 (Revision 2002-05). Torque values are derived at 3060 RPM; horsepower values are derived at 3600 RPM. The gross power curves can be viewed at www.BRIGGSandSTRATTON.COM. Net power values are taken with exhaust and air cleaner installed whereas gross power values are collected without these attachments. Actual gross engine power will be higher than net engine power and is affected by, among other things, ambient operating conditions and engine-to-engine variability. Given the wide array of products on which engines are placed, the gas engine may not develop the rated gross power when used in a given piece of power equipment. This difference is due to a variety of factors including, but not limited to, the variety of engine components (air cleaner, exhaust, charging, cooling, carburetor, fuel pump, etc.), application limitations, ambient operating conditions (temperature, humidity, altitude), and engine-to-engine variability. Due to manufacturing and capacity limitations, Briggs & Stratton may substitute an engine of higher rated power for this Series engine.

* This generator is rated in accordance with CSA (Canadian Standards Association) standard C22.2 No. 100-04 (motors and generators).

Briggs & Stratton Power Products Group, LLC
P.O. Box 702
Milwaukee, Wisconsin, 53201-0702 U.S.A.